

Some Developments (Projects)

High-Speed-Inline-Galvanic

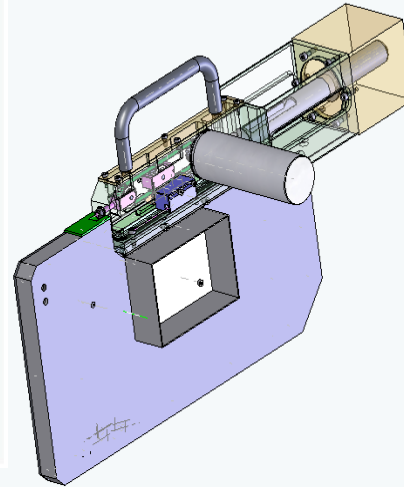

Ultra-Sonic-Device



Cable Storage

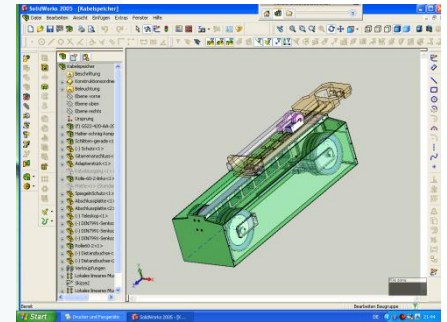

US-Shuttle



Chip Fixing for Soccer Ball Planned for Soccer-World Championship 2006



REORGANISATION OF ASSEMBLY ITW- *CRONES* Ansbach

MRD- induced supply chain management for KANBAN -Production

possible workload scenario in 2005 quartal outlook

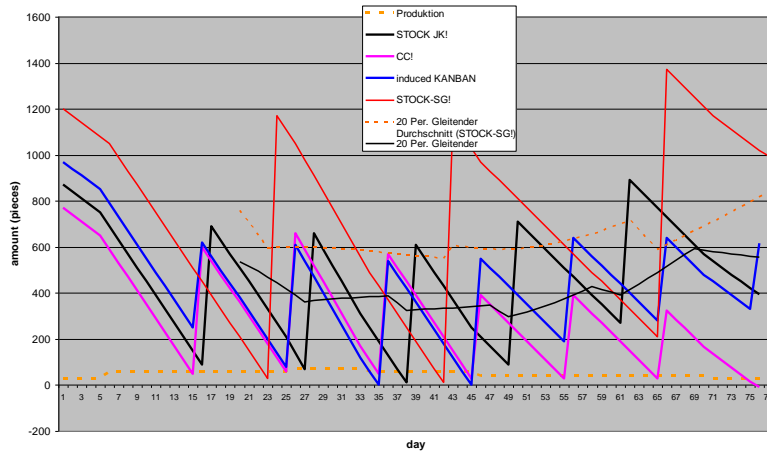

2-LAYER-KANBAN-STOCK
80/20
Compact and flexible
JUST IN TIME Assembling



Management Task „Renovation“

- Evaluating a Support Construction together with external Engineers
- Projectmanagement together with the Unit-Manager
- Responsible for electrical Energy Supply (Planning, Installation, Controlling)



Development of Electro Power Tools

Designing the plastic Parts of a a new
8kg Hammer and 5 kg Hammer

SRC-Electronic Feature to
improve the Safety

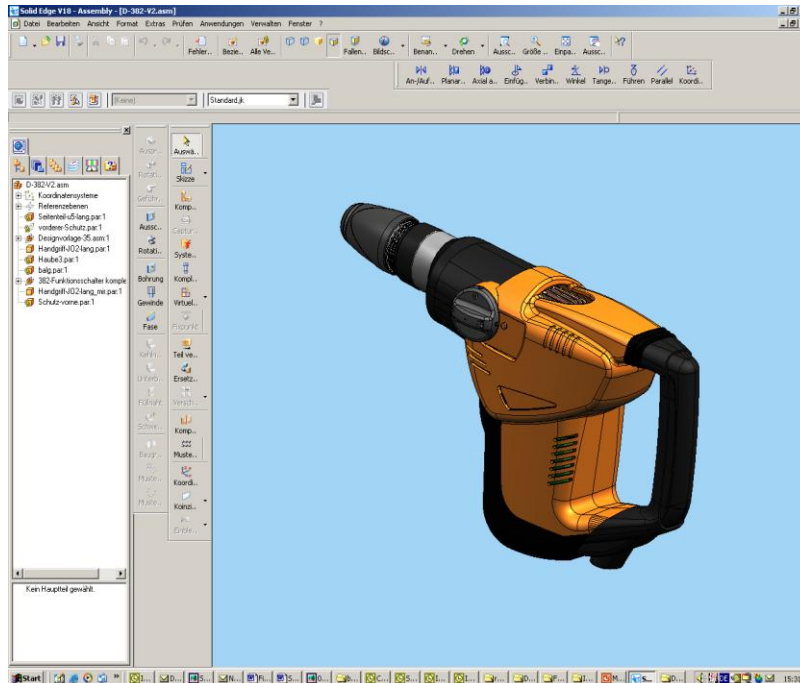

Concept - scalable Assembly Line

Target: minimum Production Costs according to Sales Forecast

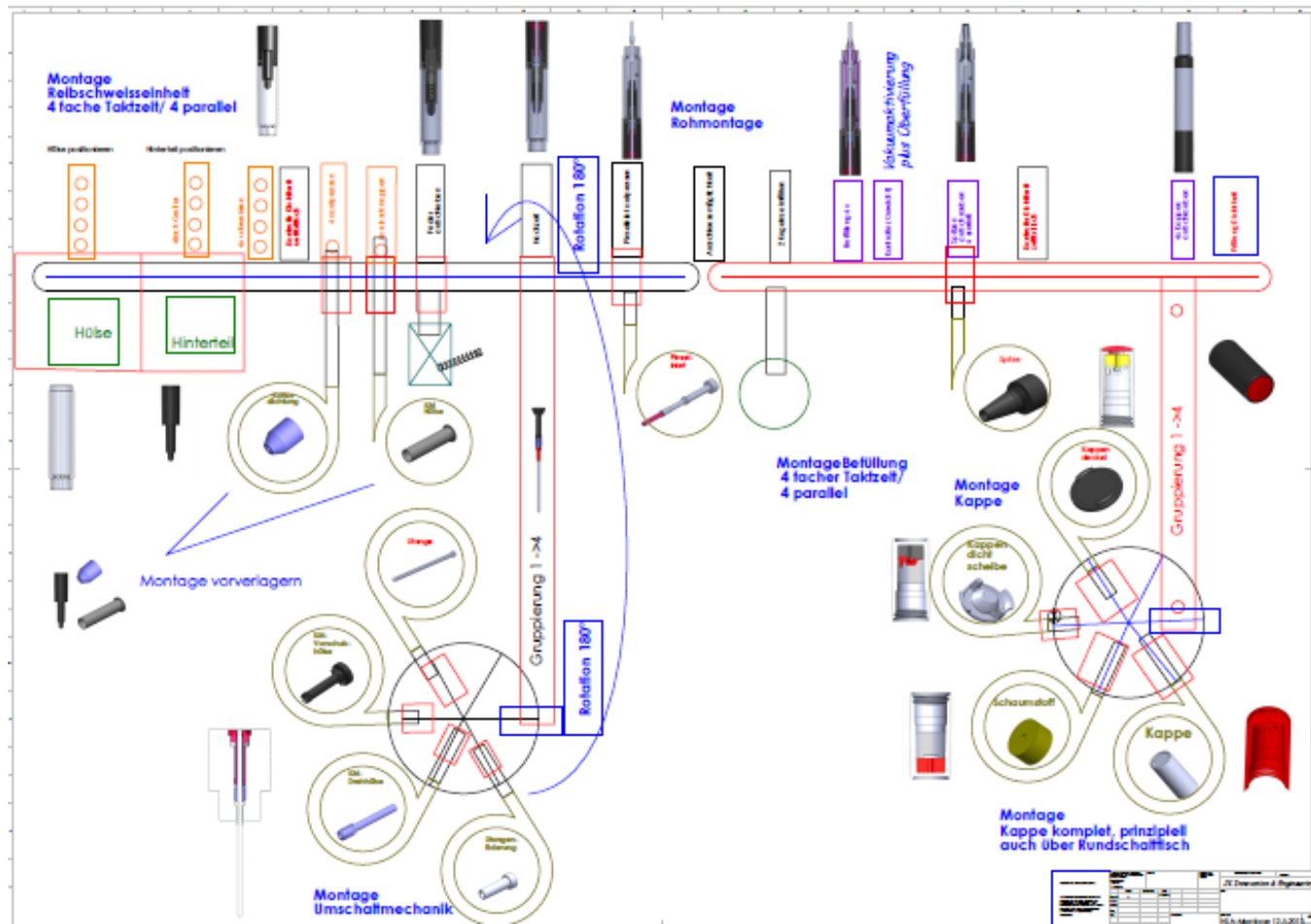

Hybrid Prototyping / DLP-Printing

Pre-Serial Product for Cosmetic Industry



Hybrid-Prototype (with 3D printed parts)



3D Printing

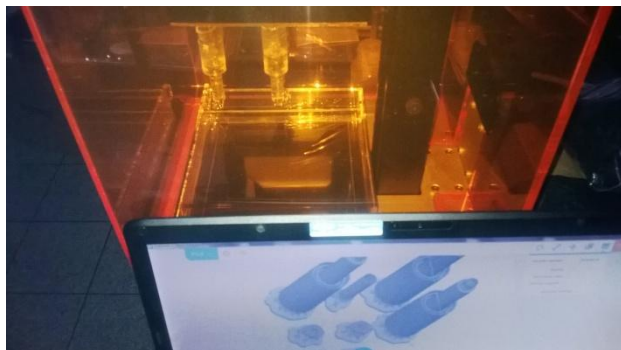

First Prototype of a new HH-Generator

